

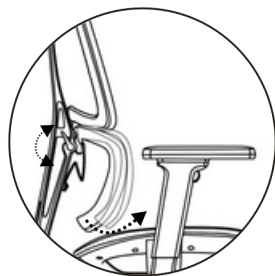

Introduction

ERGO (ZM-716A/ZM-716B)

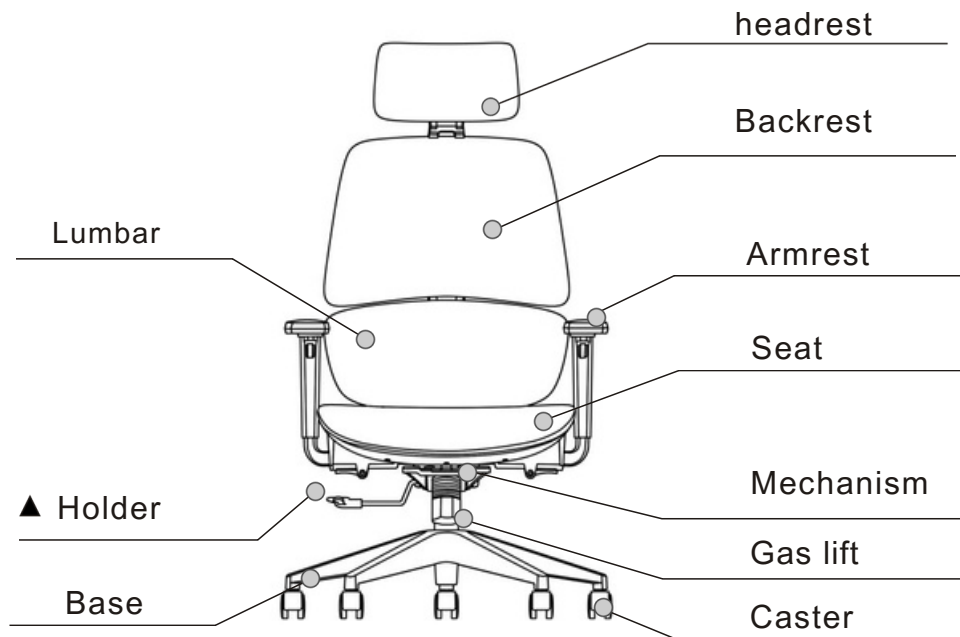

Adjustable lumbar

A handle behind the lumbar which for adjusting the radian to support your back.

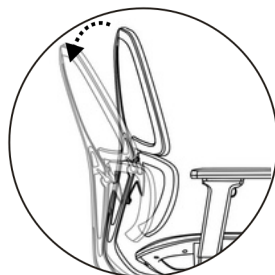

Backrest

22-25 degree of tilting angle be offer from the mechanism, more comfort more support from the backrest.

Armrest

3D armrest:width adjustable panel movable & revolve with both side.

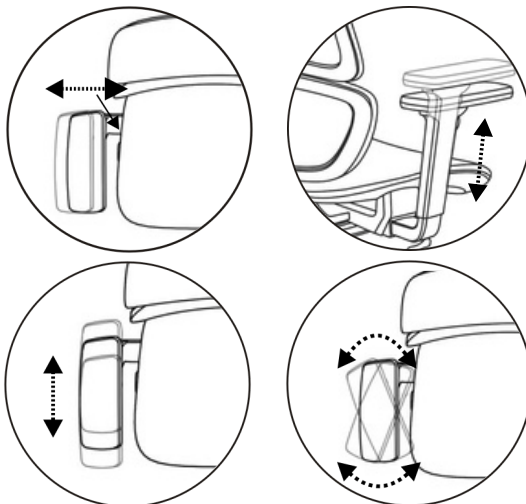

Headrest for adjustable

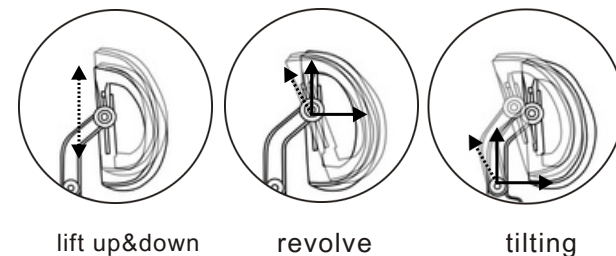

Assembly instruction

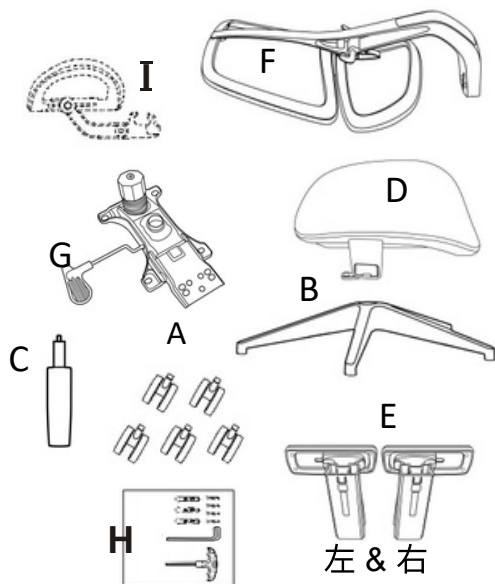

A-caster
 B-five star base
 C-gas lift
 D-seat
 E-handrest
 F-backrest
 G-mechanism
 H-tool&screws
 I-headrest

M8*45-3pcs
 M8*30-4pcs

Step-1



Fix the casters(A) into the five star base(B).

Step-2

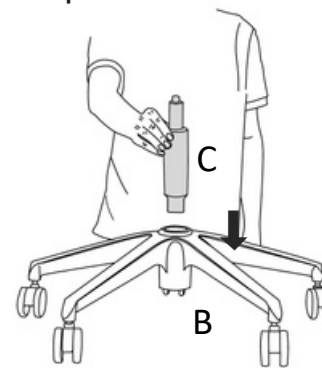

Put the gas lift (C) into the center hole of the base(B).

Step-3

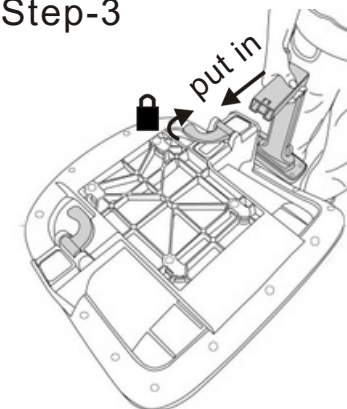

Secure the handrest(E) without screw on the seat(D). Attention to choose the Right or Left one on the correct side.

Step-4

4pcs screw
 M8*30mm

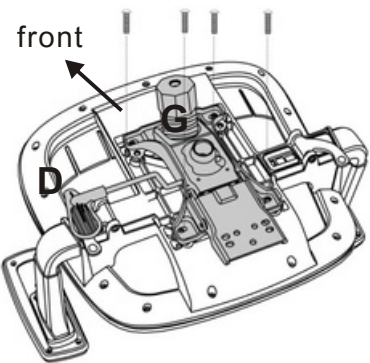

Put the mechanism on the seat(D) and secure it attach on seat(D) with 4 screws.

Step-5

3pcs screw
 M8*45mm

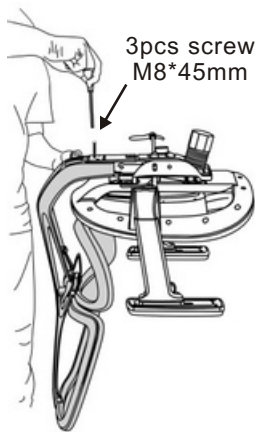

Secure the backrest(F) attach in the seat joint(D) with 3 screws.

Step-6

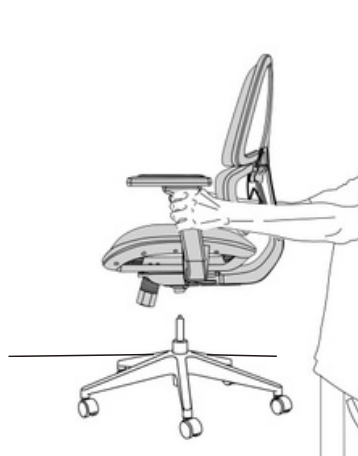

Turn the assembled seat upright and locate the center hold of the mechanism over the seat post.

Assemble maching of with headrest.

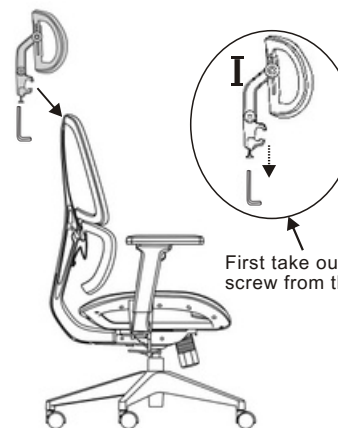

First take out the screw from the part of headrest(I), Second, fits the headrest on the backrest.



Completed. Lift the right side holder can get the height your need. Nice day.